

Worm Gear Screw Jacks

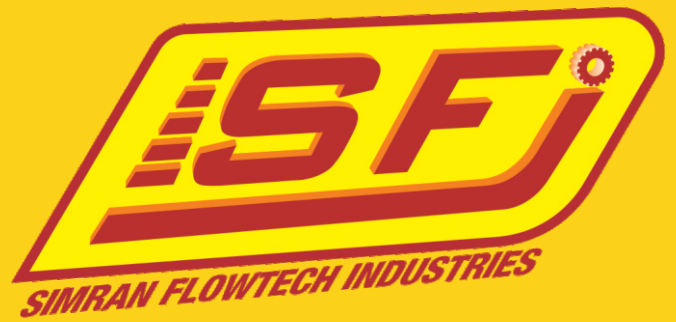

Product Catalogue 2012

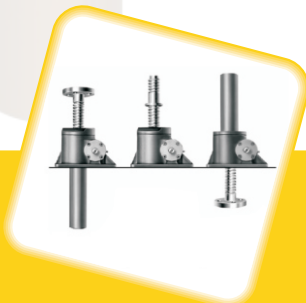
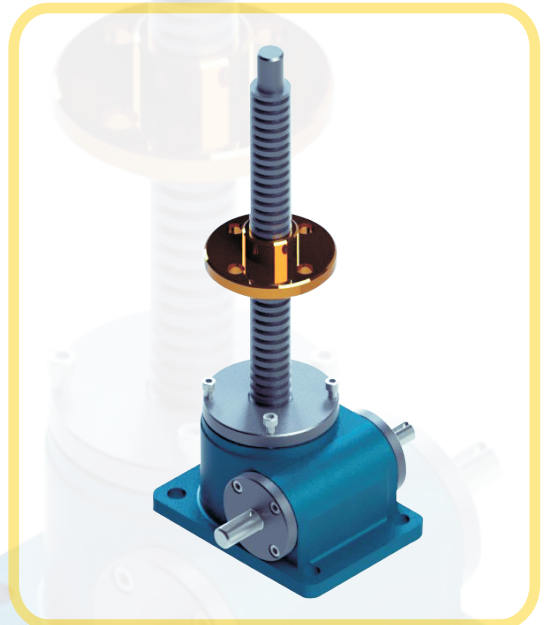
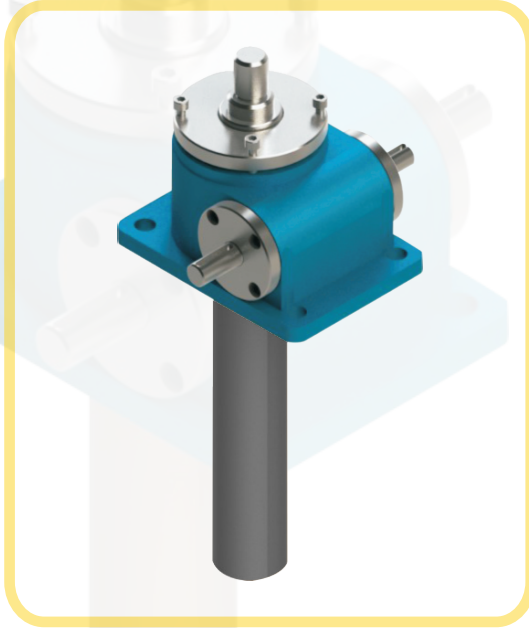

ISO 9001:2008

Simran Flowtech Industries

Plot No. 174, Sector-24, Industrial Area,
Faridabad - 121005 Haryana, INDIA
Telefax : 91-129-4028353, 4315298
E-mail : info@simranflowtech.com
Website: www.simranflowtech.com

PRELIMINARY SELECTION GUIDE SWJM SERIES

Translating Screw



Type 1 Design A

Translating Screw



Type 1 Design B

Rotating Screw



Type 2 Design A

Rotating Screw



Type 2 Design B

Model No. & Capacity in Metric Tonnes		0.5	1	2	2.5	5	10	15	20	25	30	35	50	75	100	150
Max. Lifting Force KN		5	10	20	25	50	100	150	200	250	300	350	500	750	1000	1500
Lifting Screw Dia & Pitch mm		18 x 4	22 x 5	30 x 6	30 x 6	40 x 7	58 x 12	60 x 12	65 x 12	90 x 16	95 x 16	100 x 16	120 x 16	127 x 16	160 x 20	180 x 25
Worm Gear Ratio	Normal	10 : 1	5 : 1	6 : 1	6 : 1	6 : 1	6 : 1	6 : 1	8 : 1	32 : 3	32 : 3	32 : 3	32 : 3	32 : 3	12 : 1	12 : 1
	Slow	20 : 1	20 : 1	24 : 1	24 : 1	24 : 1	24 : 1	24 : 1	24 : 1	32 : 1	32 : 1	32 : 1	32 : 1	32 : 1	36 : 1	36 : 1
Lift in mm per turn of input shaft	Normal	0.4	1	1	1.0	1.167	2.0	2.0	1.5	1.5	1.5	1.5	1.5	1.5	1.667	2.08
	Slow	0.2	0.25	0.25	0.250	0.292	0.5	0.5	0.5	0.5	0.5	0.5	0.5	0.5	0.566	0.694
Max. Power input (KW) *	20% Duty	0.12	0.24	0.45	0.55	1.1	2.6	2.6	3.7	4.8	4.8	6.0	7.4	9	12.5	25
	10% Duty	0.17	0.32	0.63	0.75	1.5	3.7	3.7	5.2	6.7	6.7	8.4	10.4	13.5	17.5	17.5
Total Efficiency Rating %	Normal	27.2	27	26.4	23.2	21	23	22.5	21.5	20	19	18	15	15	15	15
	Slow	20	16	16	13.6	16	16	16	15	12	12	11.0	10.0	10	9.0	9
Screw Torque (Nm) *	At Max. Lift	8.8	17.3	44.6	60	153	468	717	1009	1725	2148	2500	4236	6630	11116	19270
Max. Permissible Torque (Nm) At Driving Shaft		12	20.5	36	46.5	92	195	195	280	480	480	705	840	1200	2660	4220
Weight without Screw & Protection Tune (kg)		1.2	1.2	7.3	7.3	16.2	25	25	36	70.5	70.5	87	176	538	538	538
Weight per 100 mm Screw		0.14	0.17	0.32	0.45	0.82	1.67	1.8	2.15	4.15	4.62	5.20	7.70	8.62	13.82	18.6

SELECTION OF APPROPRIATE SCREW JACK

The technical characteristics required of each screw jacks need to be studied. While selecting the screw jack following criteria is used:

1. Always take a screw jack of greater capacity than actually required.
2. Verify the buckling force on the lifting screw in case the load exerts compressive force on screw.

$$P_c = \frac{\pi^2 * E * 0.05 * d^4}{L^2}$$

P_c = Critical Load x safety coefficient (Between 3 & 5)

E = Elastic modulus of screw material (Generally = 2 x 10⁴)

L = Distance between the guiding point of lift screw where the load is guided.

For Free/Unguided Loads take L = 2 x Stroke Length required.

3. Calculate the power absorbed by the Jack by applying the following formula:

$$P(HP) = \frac{\text{Load (Tons)} \times \text{Lifting Speed mm/min}}{4500 \times \text{Efficiency of Jack (Refer Table -1)}}$$

Verify that this power does not exceed the maximum indicated power of the screw jack. If the same is greater you need to select the greater capacity jack or else lessen the lifting speed.

4. In case where several jacks are to be used in tandem apply the following formula to calculate power required.

$$\text{Total P (HP)} = x \frac{P \text{ absorbed by each jack} \times \text{number of jacks required}}{\text{Overall efficiency of installation} * \text{Efficiency of Angle Drives**}}$$

- * For 2 Jacks = 0.95, for 3 Jacks = 0.9, for 4 Jacks = 0.85, for 6 Jacks = 0.80
- ** Take 0.90 per angle drive.

5. Verify maximum lifting speed V in mm/min.

$$V \text{ (mm/min)} = 4.5 \times 10^3 \times \frac{\text{Max power per Jack (HP)} \times \text{Efficiency of Jack}}{\text{Load per Jack (Tons)}}$$

Notes:

1. To restrain horizontal stress or to reduce the radial play of the lifting screw, optional second guide ring can be provided upon request.
2. If the jacks are to be subjected to vibrations, take a greatest reduction ratio or slower raise speed.

Order Information

JACK SERIES	CAPACITY		GEAR RATIO	
	METRIC TONS	KN	Normal	Slow
SWJM	0.5	0005	10:1	20:1
SWJM	1	0010	5:1	20:1
SWJM	2	0020	6:1	24:1
SWJM	2.5	0025	6:1	24:1
SWJM	5	0050	6:1	24:1
SWJM	10	0100	6:1	24:1
SWJM	15	0150	6:1	24:1
SWJM	20	0200	8:1	24:1
SWJM	25	0250	32:3	32:1
SWJM	30	0300	32:3	32:1
SWJM	35	0350	32:3	32:1
SWJM	50	0500	32:3	32:1
SWJM	75	0750	32:3	32:1
SWJM	100	1000	12:1	36:1
SWJM	150	1500	12:1	36:1

Heads

TYPE - I



TYPE - IV

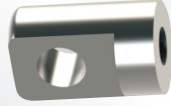

TYPE - II



TYPE - V



TYPE - III

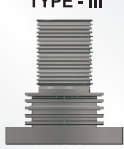

TYPE - VI



Accessories



Anti-Backlash



Hand Wheel



Gear Coupling



Gear Motor





Bellow Boot



Bevel Gear Box

MODEL	TYPE	DESIGN	0025	GEAR RATIO	STROKE	HEAD	ACCESSORIES
SWJM	2	A	2.5 TON	6:1	200mm	TYPE-II	HAND WHEEL

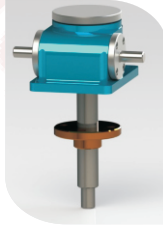
Type 1 Translating Screw		Type 2 Rotating Screw	
Design A		Design A	
Design B		Design B	

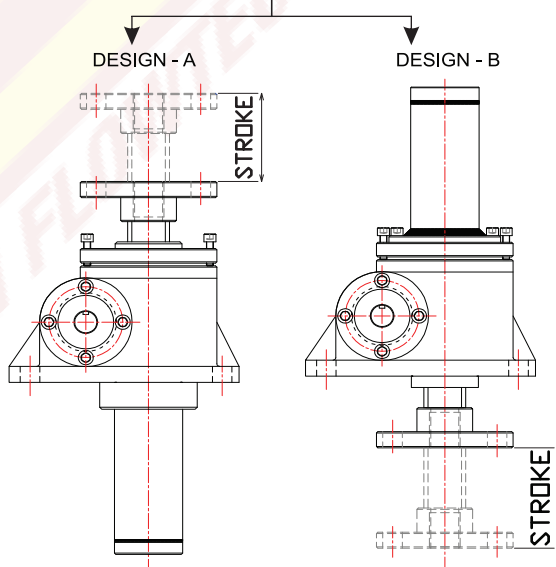

Dimension Drawings

Dimension Table Type 1 & Type 2

TYPE 1 DESIGN A

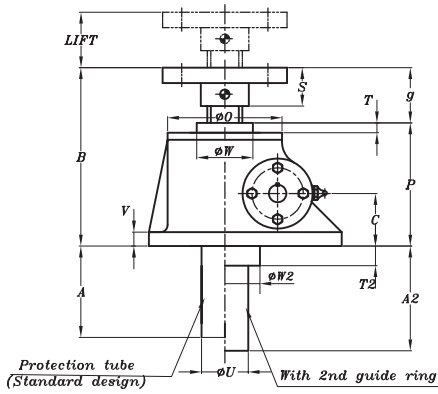

TYPE 2 DESIGN A

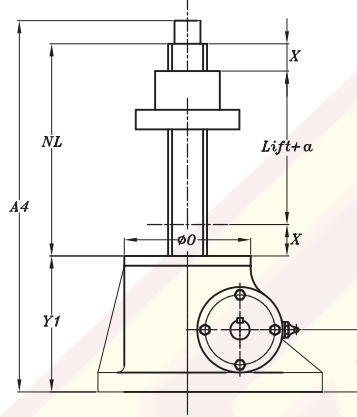

ONLY FOR SWJM-0.5

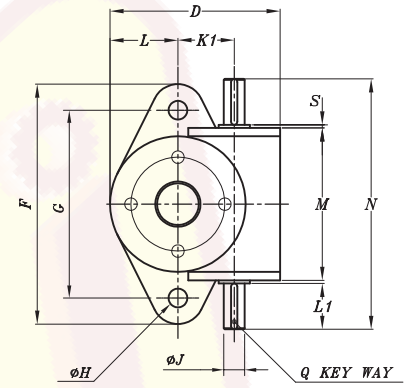

TYPE 1 DESIGN B

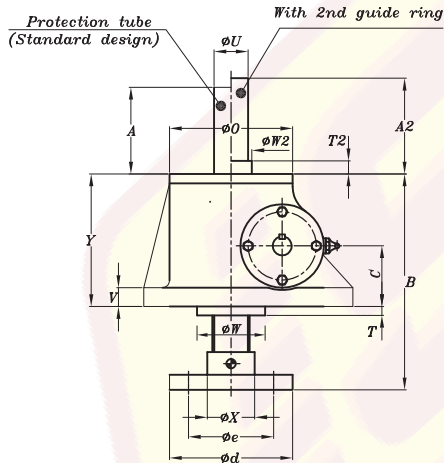

TYPE 2 DESIGN B

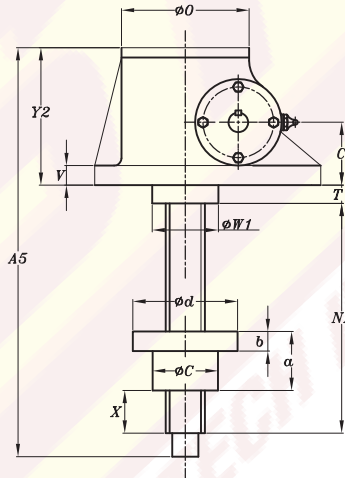

ONLY FOR SWJM-2

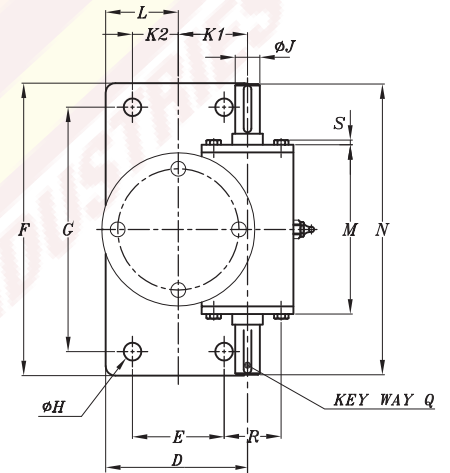

ONLY FOR SWJM-2.5, 5, 10, 15, 20, 25, 30 35 & 75

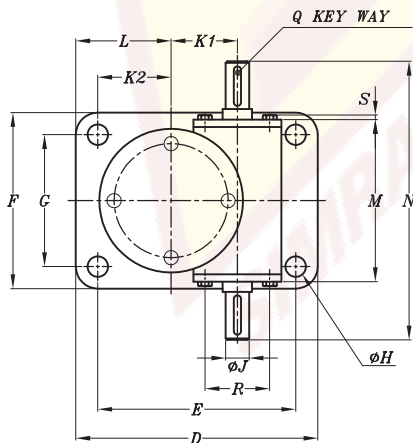

ONLY FOR SWJM-50

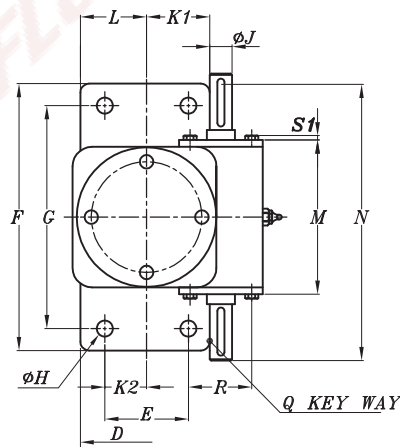

ONLY FOR SWJM- 100 & 150

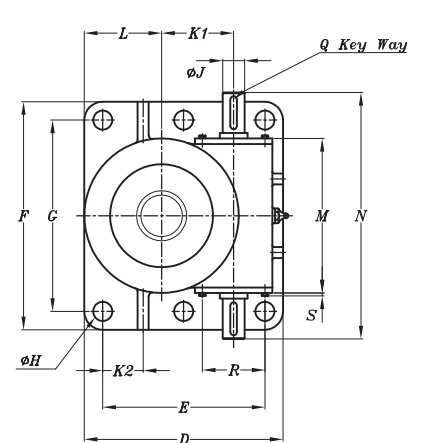

DIMENSION TABLE

All dimensions are in mm

Frame Size	0.5	2	2.5	5	10	20	25	35	50	100	150
A	LIFT + 20	LIFT + 20	LIFT + 20	LIFT + 20	LIFT + 20	LIFT + 20	LIFT + 20	LIFT + 20	LIFT + 20	LIFT+65	LIFT + 65
A2	LIFT + 50	LIFT + 50	LIFT + 50	LIFT + 50	LIFT + 50	LIFT + 50	LIFT + 65	LIFT + 65	LIFT + 65	LIFT + 65	LIFT + 65
A4	LIFT + 166	LIFT + 205	LIFT + 214	LIFT + 270	LIFT + 335	LIFT + 404	LIFT + 476	LIFT + 535	LIFT + 643	LIFT + 802	LIFT + 802
A5	LIFT + 188	LIFT + 227	LIFT + 238.5	LIFT + 300	LIFT + 359	LIFT + 430	LIFT + 513	LIFT + 580	LIFT +675	LIFT + 812	LIFT + 812
B	105.5	139	150	193	230	262	317	350	400	500	550
C	32	44	45	61.5	70	87	102	115	130	170	170
D	81.5	100.5	165	210	235	295	350	430	260	540	540
E	-	57	135	168	190	240	280	360	150	440	440
F	115	182	120	154	200	215	260	280	500	620	620
G	90	152	90	114	155	160	190	210	400	520	520
ØJK6	10	14	16	20	25	28	35	38	40	60 m6	47-62 K6
K1	27	45	45	56.2	66.8	72.5	97	120	137	196	196
K2	-	28.5	50	58	63.5	95	95	135	75	160	160
L	32.5	47	65	80	86	122.5	130	170	130	210	210
M	73	100.5	120.5	150	174	213.5	245	265	320	420	420
N	120	180	190	227	280	322	355	430	560	670	670
NL	LIFT+72	LIFT+80	LIFT+85	LIFT+110	LIFT+125	LIFT+150	LIFT+170	LIFT+205	LIFT+225	LIFT+300	LIFT+300
ØO	65	98	98	122	150	185	205	260	300	440	440
P	75.5	101.5	10.5	142	156.5	186	225	250	275	360	360
Q	3x3x20	5x5x28	5x5x30	6x6x32	8x7x45	8x7x45	10x8x50	10x8x50	12x8x80	18x11x90	18x6x75
ØR	-	53	53	65	76	90	110	132	115	168	168
S	1.5	6	5.5	6	7	6	10	10	12	14	14
T	5.5	8.5	8.5	12	6.5	6	8	10	15	20	20
T1	22.5	24	26.5	30	34	39	52	45	29	43	43
T2	11.5	20	20	25	18	31	40	40	10	20	20
T4	0	0	0	0	0	0	0	15	32	0	0
ØU	26.7	48.3	48.3	60.3	76	88.9	114.3	141.3	168.3	219.1	219.1
V	10	13	12	18	16	20	25	30	35	50	50
ØW	36	40	40	60	80	100	130	150	170	240	240
ØW1	45	60	68	83	110	140	160	180	210	280	280
ØW2	45	60	60	75	95	100	130	150	159	220	220
X	20	20	20	20	25	25	25	30	50	50	50
Y	70	93	100	115	150	176	217	240	260	360	360
Y1	74	95	100	129	160	194	226	250	289	383	383
Y2	70	93	100	129	150	181	211	250	292	360	360

Head Types

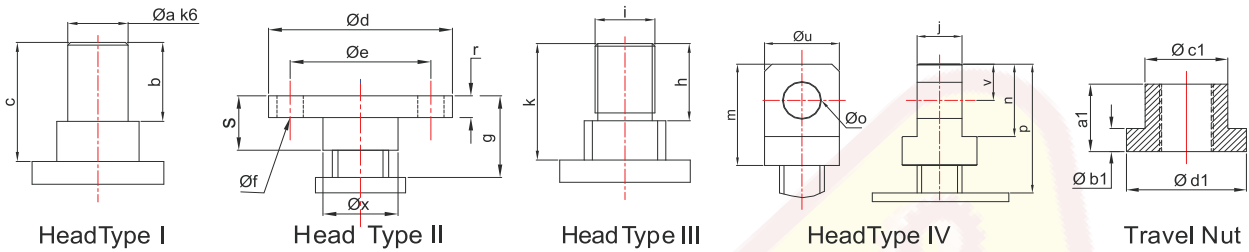

CAPACITY IN MATRIC TONS		0.5	2	2.5	5	10	20	25	35	50	100	150
HEAD I	Øa	12	18	20	25	40	50	70	80	100	140	150
	b	20	30	30	40	50	60	63	80	125	175	175
	c	30	46	45	51	73.3	80	92	100	150	200	225
HEAD II	Ød	65	98	98	122	150	185	205	260	300	370	355
	Øe	45	75	75	85	105	140	155	200	225	280	280
	Øf	4xØ7	4xØ11	4xØ14	4xØ17	4xØ21	4xØ26	4xØ27	4xØ33	4xØ35	6xØ52	6xØ48
	r	8	12	12	18	20	20	25	30	30	75	75
	s	20	30	30	40	50	60	63	80	70	125	125
	Øx	18	40	40	50	65	90	100	130	140	200	200
	g	30	46	45	51	73.3	80	92	100	100	150	200
	h	20	30	30	59	50	60	63	80	125	175	175
HEAD III	i	M12x1.25	M18x1.5	M22x1.5	M30x2	M40x3	M50x3	M70x3	M80x3	M100x5	M140x6	M150x6
	k	30	46	45	51	73.3	80	92	100	150	200	220
HEAD IV	l	20	30	30	42	60	75	90	185	120	160	180
	m	50	70	70	105	130	150	175	220	300	360	375
	n	30	50	50	75	100	120	140	160	200	280	300
	Øo H8	15	20	25	35	50	60	70	80	100	145	160
	p	65	86	85	117	153.5	170	204	240	325	385	400
	Øu	30	48	50	65	90	110	130	150	170	220	280
	v	15	25	25	37.5	50	60	70	80	100	140	150
TRAVEL NUT	a1	32	40	45	60	75	100	120	145	155	200	225
	b1	10	18	15	18	25	70	35	35	50	80	65
	Øc1	40	50	50	70	90	90	130	150	160	200	230
	Ød1	50	76	80	87	110	120	155	190	225	260	395

General Instructions

Maintenance and installation recommendations

In order to ensure that the actuator give good service over a period of years the following precautions should be taken.

1. Select an actuator, which has a rated capacity greater than the maximum load that may be imposed on it.
2. The structure on which the actuators are mounted have ample strength to carry the maximum load, and should be rigid enough to prevent undue deflection or distortion of the actuator supporting numbers.
4. The actuators should have a greater raise than is needed in the actual installation. Should it be necessary to operate the actuators at the extreme limits of travel it should be done cautiously?
6. The maximum worm shaft speed for these actuators should not exceed 500 R.P.M. for heavy loads.
7. The lifting screws should not be permitted to accumulate dust and grit on the threads. If possible, lifting screw should be returned to the closed height position when not in use.
9. The actuators are shipped packed with grease (unless otherwise called for) which should be sufficient for one month using one of the extreme pressure grease or their equivalent.
10. For severe service conditions the actuator should be lubricated with a molybdenum disulphide type of grease about once a week.

ACCESSORIES GEAR COUPLING

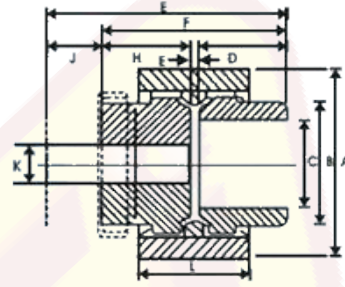

GEAR COUPLING.

SIZE (TONS)	0.5	1	2	2.5	5	10	15	20	25	30	35	50	75	100	150
MODEL	H-19	H-19	H-19	H-19	H-28	H-28	H-28	H-28	H-38	H-38	H-38	H-48	H-48	H-65	-
A	48	48	48	48	66	66	66	66	83	83	83	100	100	140	-
B	30	30	30	30	44	44	44	44	56	56	56	68	68	96	-
F	54	54	54	54	81.8	81.8	81.8	81.8	81.8	81.8	81.8	100.8	100.8	143.5	-
L	37	37	37	37	46	46	46	46	48	48	48	50	50	72	-

LOVE JOY COUPLING.

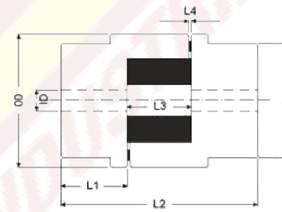
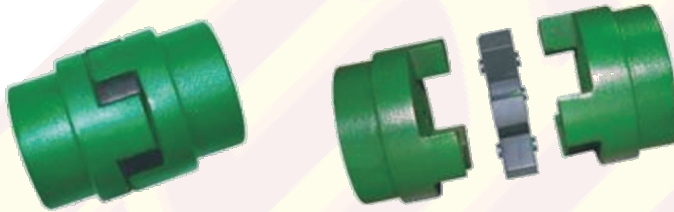

LOVE JOY COUPLING.

SIZE (TONS)	0.5	1	2	2.5	5	10	15	20	25	30	35	50	75	100	150
MODEL	CP-50	CP-50	CP-70	CP-70	CP-75	CP-95	CP-99/100	CP-110	CP-110	CP-110	CP-150	CP-190	CP-225	-	-
L1	15	15	19	19	21	25	35	43	43	43	45	54	64	-	-
L2	42	42	51	51	56	63	88	108	108	108	115	133	153	-	-
OD	27	27	36	36	44.5	54	65	85	85	85	96	115	127	-	-

HAND WHEEL

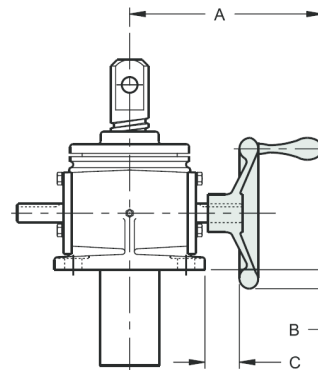

HAND WHEEL.

SIZE (TONS)	0.5	1	2	2.5	5	10	15	20	25	30	35	50	75	100	150
DIAMETER	4"	4"	6"	6"	8"	10"	12"	12"	-	-	-	-	-	-	-
A	4 5/8	5 3/8	7 1/4	7 1/4	8 3/4	10 1/4	10 1/4	10 5/8	Standard Motors are recommended						
B	1	1/2	1 1/4	1 1/4	1 3/4	2 3/4	2 1/4	2 3/4							
C	3/8	5/8	3/8	1 7/8	1 7/8	2 3/8	2 1/4	2 3/8							

Applications of Worm Gear Screw Jacks



Barge Gate

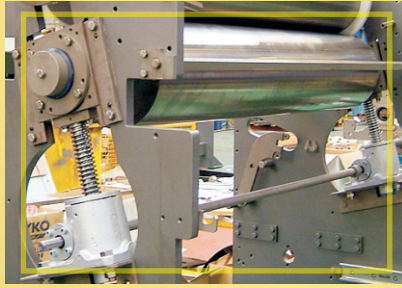

Roller Adjustment



Precision Assembly



Solar Panels



Actuation

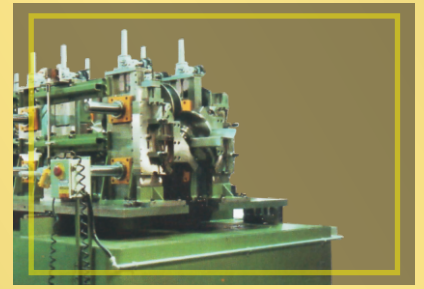

Roll Forming Line

Our Other Products



Hydraulic Cylinder



Rotary Union



Power pack



Jacks Assembly



Over Velocity Device



Hydraulic Jack

Simran Flowtech Industries has a Policy of Continual Product Development & therefore reserves the right to modify Products Shown in the Catalogue. Please treat all Dimension therefore as indicative.

Represented By :

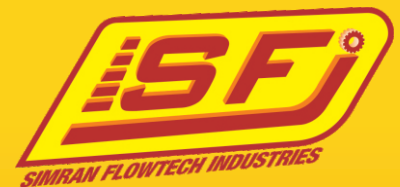

Simran Flowtech Industries

Plot No. 174, Sector-24, Industrial Area,
Faridabad - 121005 Haryana, INDIA
Telefax : 91-129-4028353, 4315298
E-mail : info@simranflowtech.com
Website: www.simranflowtech.com